



krafton[®] bridge deck plank 236.40

Assessment according to Eurocode NL

Client	:	krafton [®]
Execution	:	ing. J.H.A. Zijderveld
Authorized	:	ing. D.A. Mager
Report no.	:	R_10694-1
Issue	:	1
Date	:	23-03-2023

Table of contents

1	Summary.....	4
2	Product description	8
2.1	Geometric properties.....	8
2.2	Mechanical properties	9
3	Requirements	10
3.1	Standards and recommendations.....	10
3.2	National Annex Netherlands.....	10
3.3	Loads	11
3.4	Requirements.....	12
3.5	Load combinations.....	14
4	Symbols.....	17
5	Verification of allowable span on 2 supports	18
5.1	Self-weight	18
5.2	Distributed mobile load	19
5.3	Concentrated load	21
5.4	Service vehicle.....	23
5.5	Snow.....	32
5.6	Accidental vehicle	34
5.7	Summary	41
6	Verification of allowable span on 3 or more supports	43
6.1	Self-weight	43
6.2	Distributed mobile load	44
6.3	Concentrated load	46
6.4	Service vehicle.....	49
6.5	Snow.....	54
6.6	Accidental vehicle	55
6.7	Summary	60
7	Comfort.....	62
8	Conclusion	63
	Appendix A: Properties of the bridge deck plank.....	64
A.1	Summary	64
A.2	Tests	65
A.2.1	Description of tests.....	65
A.3	Test results	66
A.3.1	Flexural modulus.....	67
A.3.2	Flexural strength single span	68
A.3.3	Flexural strength multi-span.....	69
A.3.4	Shear strength	70
A.3.5	Shear strength for a concentrated load on 200x200 mm	71
A.3.6	Shear strength for a concentrated load on 100x100 mm	72

Issue management

Issue	Comments	Date
1	First issue	23-03-2023

1 Summary

The mechanical properties were used to determine the maximum span of the bridge deck plank for loads from the Dutch National Annex of EN1991-2 and for multiple deflection requirements. The following situations were reported:

Multiple single spans:



One single span:

(Plank = entire bridge width)

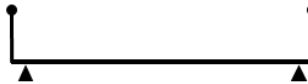

(Multiple) multi-spans¹:



The maximum span recommendations for plank 236.40 are:

	Multiple single spans	One single span	Multiple multi-spans
Without vehicles	1050 mm	1050 mm	1240 mm
Only service vehicle	550 mm	N/A	650 mm
Only accidental vehicle	220 mm	N/A	220 mm
Service and accidental vehicle	220 mm	N/A	220 mm

On the following pages, the results of the maximum span recommendations are presented in graph form. When a span is chosen in combination with a deflection requirement below the relevant lines in the graph, the krafton® 236.40 meets the specified requirements for a bridge deck plank in accordance with Eurocode for use as a bicycle - pedestrian bridge deck in consequence class CC2.

The analysis for 3 or more supports assumes supports at equal distance from each other.

The maximum allowable cantilever for every situation is 75 mm.

Note:

- A minimum deflection requirement of $L/200$ has been used for the service vehicle
- Deflection analysis for service vehicles on multi-span planks is according to situation 1, as per figure 1. In case situation 2 can occur, an additional analysis needs to be performed.

¹ A multi-span is a situation where the bridge deck plank continues uninterrupted over at least 3 supports. A connection is made at the support that sufficiently fixes the plank in the vertical direction, both upwards and downwards.

Serviceability Limit State (BGT)

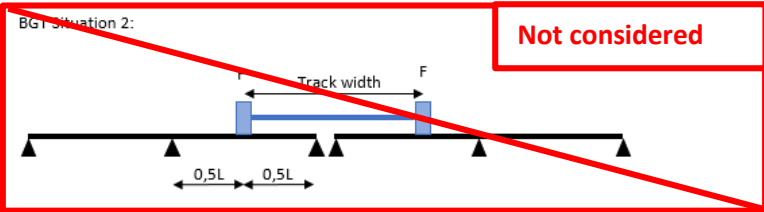
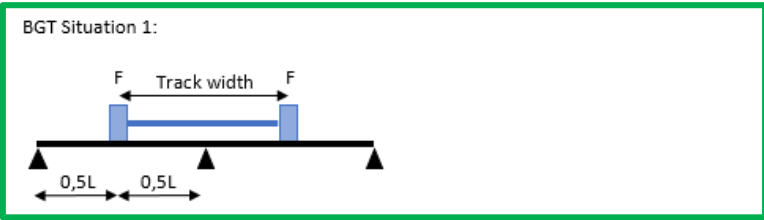

Ultimate Limit State (UGT)

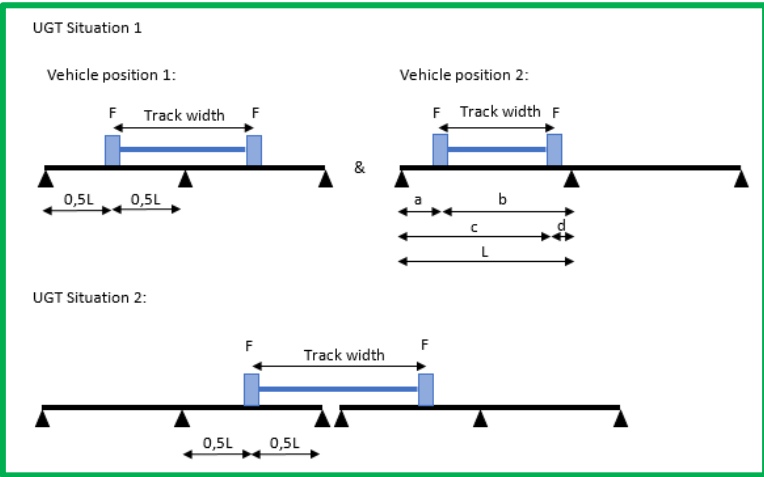

figure 1: Considered situations service- and accidental vehicle multi-span BGT and UGT

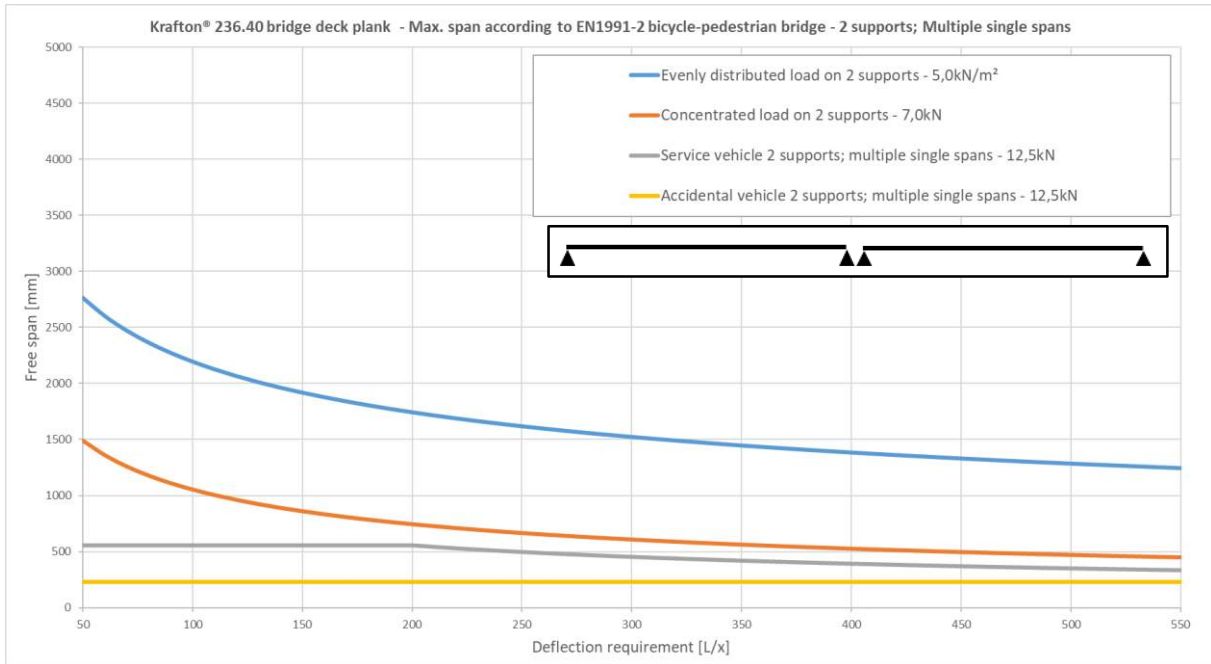

figure 2: Maximum span as a function of deflection requirements; 2 supports; multiple single spans

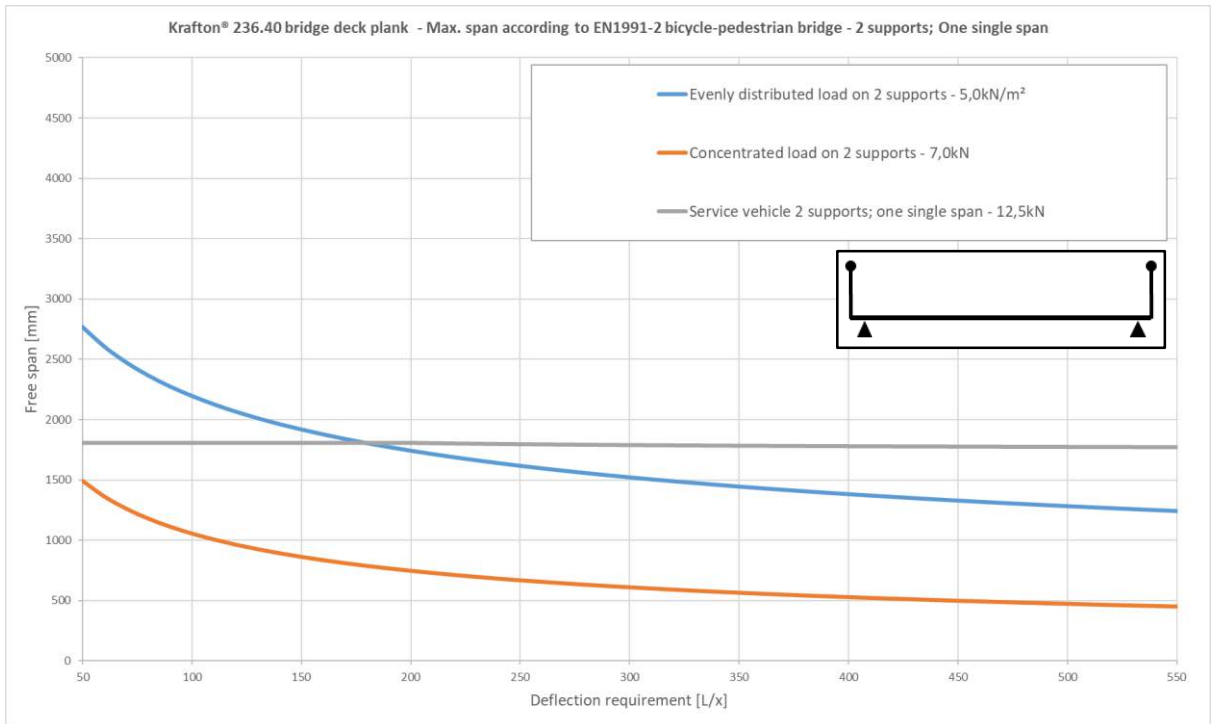

figure 3: Maximum span as a function of deflection requirements; 2 supports; one single span

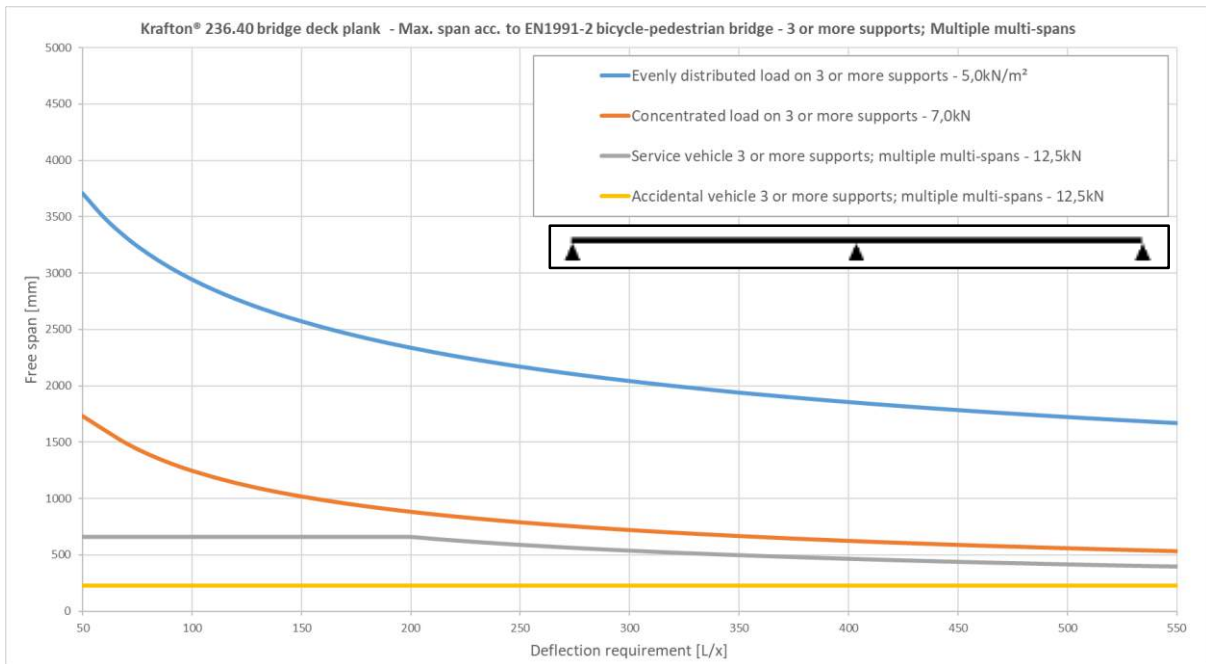

figure 4: Maximum span as a function of deflection requirements; 3 or more supports

For questions or special applications, please contact:

krafton®

Markweg Zuid 34
4794 SN Heijningen

T +31 (0) 168227510

E / info@krafton.nl

2 Product description

Pultruded, glass fibre reinforced polyester bridge deck plank.

A cross section of the plank is shown in figure 5.

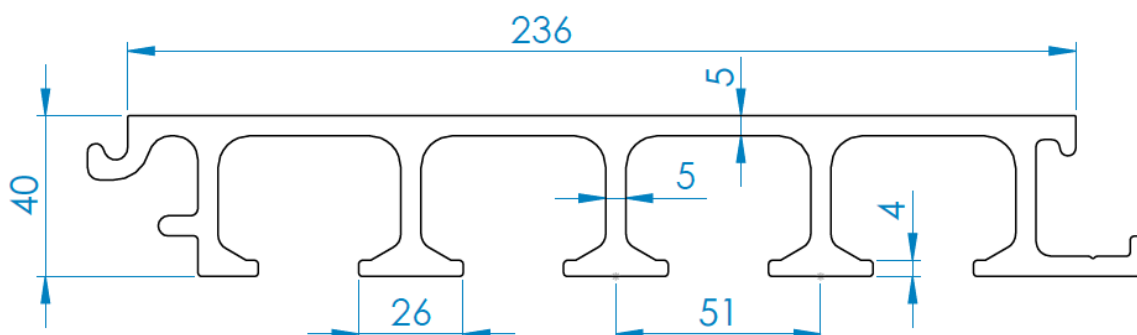

figure 5: Geometry plank 236.40

2.1 Geometric properties

Width	b	236 mm
Height	h	40 mm
Number of ribs	n	5 -
Rib spacing	d	51 mm
Sectional area	A	2986 mm ²
Shear area	A _s	1052 mm ²
Moment of inertia	I	625197 mm ⁴
Section modulus	W	26593 mm ³
Weight of plank	G	22,8 kg/m ²

2.2 Mechanical properties

The characteristic mechanical properties are shown in table 1, complete mechanical properties can be found in Appendix A: Properties of the bridge deck plank.

table 1: Characteristic mechanical properties

		Unit	krafton® 236.40
Modulus of elasticity	($E_{b, kar}$)	N/mm ²	32130
Flexural stress ²	($\sigma_{b, kar}$)	N/mm ²	266
Shear stress	(τ_{kar})	N/mm ²	51,2
Shear force on 100x100mm	($D_{kar, 100}$)	N	33658
Shear force on 200x200mm	($D_{kar, 200}$)	N	51886

²Lowest value of single- and multispan tests.

3 Requirements

3.1 Standards and recommendations

The bridge deck plank has been assessed according to the following standards and recommendations.

Standard	Title	Issue
NEN-EN 1990	Eurocode - Basis of structural design	2011
NEN-EN 1991-2+C1	Traffic loads on bridges	2015
NEN-EN 1991-1-3	Actions on structures - Part 1-3: General actions - Snow loads	2011
CUR recommendation 96 (2019)	Fibre-Polymer Composite Structures in Civil Applications	2019
EN 13706-3	Specification for pultruded profiles – Part 3: Specific requirements	2002

3.2 National Annex Netherlands

Standard	Title	Issue
NEN-EN 1990+A1+A1/C2/NB	Dutch National Annex to Eurocode: Fundamentals of structural design	2011
NEN-EN 1991-2+C1/NB	Dutch National Annex to Eurocode: Traffic loads on bridges	2019
NEN-EN 1991-1-3/NB	Dutch National Annex to Eurocode: Part 1-3: General loads – Snow loads	2011

3.3 Loads

3.3.1 Permanent load (G)

The permanent load on the bridge deck is caused by the weight of the bridge deck planks and the protective abrasion layer. The following masses have been used.

GRP bridge deck planks	22,8 kg/m ²	
Abrasion layer	13,0 kg/m ²	
Total permanent load	35,8 kg/m ² =	0,358 kN/m ² [G]

3.3.2 Variable load (Q)

3.3.2.1 Mobile load

Evenly distributed load	5,0 kN/m ²	[Qf]
Concentrated load	7,0 kN	[Qf;w]
Dimension concentrated load	100 x 100 mm ²	
Service vehicle		
Axle 1	25,0 kN	[Qd]
Wheel print	250 x 250 mm ²	
Axle 2	25,0 kN	
Wheel print	250 x 250 mm ²	
Track width	1750 mm	
Wheelbase	3000 mm	

3.3.2.2 Snow

Maximum possible snow load	0,7 kN/m ²	
Maximum form factor (closed railing)	2 -	
Maximum snow load	1,4 kN/m ²	[Qs]

3.3.3 Special load (A)

Accidental vehicle with the following characteristics:

Accidental vehicle of 120 kN

Axle 1	80,0 kN	[Aov]
Wheel print	200 x 200 mm	
Axle 2	40,0 kN	
Wheelprint	200 x 200 mm	
Track width	1300 mm	
Wheelbase	3000 mm	

3.4 Requirements

3.4.1 Requirements serviceability limit state

The deflection requirement can be determined separately for each project.

The verification calculation is reported for a deflection recommendation.

The deflection requirements are set for deflection due to variable loadings.

All deflection requirements up to a requirement of L/550 are calculated and reported in figure 2, figure 3 and figure 4.

The following maximum deflection recommendations are used:

- L/200 Distributed mobile load
- L/100 Concentrated load
- L/200 Service vehicle
- No deflection recommendations for other loads considered

3.4.2 Comfort

The comfort requirement is in accordance with JRC document “JRC 53443 human induced vibrations”.

Desired comfort level CL1.

Maximum allowable acceleration is 0,5 m/s². This is guaranteed when the Eigen frequency is above 5Hz. This report uses the stated Eigen frequency as a lower limit.

3.4.3 Requirements ultimate limit state

Strength requirement in accordance with CUR 96:

$$E_d \leq \frac{\eta_c \cdot R_k}{\gamma_m}$$

E_d	Design load
R_k	Characteristic resistance
η_c	Conversion factor
γ_M	Material factor

Since η_c is dependent on the duration of the load, it is included in the load combination.

$$\frac{E_d}{\eta_c} \leq \frac{R_k}{\gamma_m}$$

3.4.4 Material factor

The CUR "Recommendation 96" prescribes material factors with regard to the properties of fibre-reinforced plastics that must be taken into account when checking the ultimate limit state. These values are valid for post-cured laminates produced by pultrusion.

γ_{M1} is the partial material factor linked to geometrical deviations and modelling uncertainties in obtaining the correct material properties.

γ_{M2} is the partial material factor that takes into account uncertainties in the strength properties of the material and depends on the distribution in material properties.

$$\gamma_M = \gamma_{M1} \times \gamma_{M2}$$

$$\gamma_{M1} = 1,15 \quad \text{For strength}$$

$$\gamma_{M2} = 1,20 \quad \text{For pultrusion}$$

Resulting:

$$\gamma_M = 1,38 \quad \text{For strength} \quad (=1,15 \times 1,20)$$

3.5 Load combinations

3.5.1 Conversion factors

The CUR “Recommendation 96” 2017 prescribes conversion factors with regards to the properties of fibre-reinforced plastics that must be taken into account when checking the various limit states.

The conversion factor takes into account the anticipated effects of temperature, time, environmental influences (moisture, sunlight), duration of the load and cyclical loads on the material properties. The conversion factor can be different for each type of load (short or long term). The conversion factor η_c , is made up of:

$$\eta_c = \eta_{ct} \cdot \eta_{cm} \cdot \eta_{cv} \cdot \eta_{cf}$$

η_{ct}	=	1,0	Temperature effects (BGT ³)
η_{ct}	=	0,9	Temperature effects (UGT ⁴)
η_{cm}	=	0,9	Effects of water(vapour)
$\eta_{cv,short}$	=	1,0	Creep effects - short term (1 hour)
$\eta_{cv,middle}$	=	0,8	Creep effects - middle term (3 months)
$\eta_{cv,long}$	=	0,67	Creep effects - long term (100 years)
η_{cf}	=	0,9	Fatigue effects

Depending on the load duration and type of analysis, the conversion factors are combined, in accordance with CUR “Recommendation 96” 2019. These following conversion factors are combined with the load.

Deformation analysis (serviceability limit state):

$\eta_{c,short}$	=	0,81
$\eta_{c,middle}$	=	0,65
$\eta_{c,long}$	=	0,54

Analysis of strength (ultimate limit state):

$\eta_{c,short}$	=	0,81
$\eta_{c,middle}$	=	0,65
$\eta_{c,long}$	=	0,54

³ BGT is the Dutch abbreviation for SLS (Serviceability Limit State)

⁴ UGT is the Dutch abbreviation for ULS (Ultimate Limit State)

3.5.2 Load factors

The load factors in the serviceability limit state are equal to 1.0.

The load factors in the ultimate limit state are in accordance to consequence class **CC2**

table 2: Load factors in accordance to EN1991 NB

Gevolgsklasse	β	G			Verkeer (met $\psi = 1$)	Overig veranderlijk (met $\psi = 1$)
		$\gamma_{G,sup}$		$\gamma_{G,int}$		
		6.10a	6.10b (incl. ξ)	6.10a en 6.10b		
CC1	3,3	1,20	1,10	0,9	1,20	1,35
CC2	3,8	1,30	1,20	0,9	1,35	1,5
CC3	4,3	1,40	1,25	0,9	1,5	1,65

3.5.3 Combinations serviceability limit state (BGT)

$$BC = \frac{1}{\eta_c} \times G \text{ or } \frac{1}{\eta_c} \times Q_i$$

Wherein: η_c conversion factor strength according to CUR 96; 2019
 G permanent load (self-weight)
 Q_i variable load i

BGT 1	1/0,54 x G
BGT 2	1/0,81 x Qf
BGT 3	1/0,81 x Qf;w
BGT 4	1/0,81 x Qd

3.5.4 Combinations ultimate limit state (UGT)

$$BC = \gamma_{G;sup} \frac{1}{\eta_c} \times G + \gamma_Q \frac{1}{\eta_c} \times Q_i$$

Wherein: $\gamma_{G;sup}$ load factor permanent load according to N1990/NB
 η_c conversion factor strength according to CUR 96; 2019
 γ_Q load factor variable load according to N1990/NB
 G permanent load (self-weight)
 Q_i variable load i

UGT 1	1,30 x 1/0,54 x G
UGT 2	1,20 x 1/0,54 x G + 1,35 x 1/0,81 x Qf
UGT 3	1,20 x 1/0,54 x G + 1,35 x 1/0,81 x Qf;w
UGT 4	1,20 x 1/0,54 x G + 1,35 x 1/0,81 x Qd
UGT 5	1,20 x 1/0,54 x G + 1,50 x 1/0,65 x Qs
UGT 6	1,20 x 1/0,54 x G + 1,35 x 1/0,81 x Aov

4 Symbols

y	=	vertical deflection [mm]
$y_{\text{optr.}}$	=	occurring deflection [mm]
$y_{\text{toel.}}$	=	allowable deflection [mm]
F	=	concentrated load [N]
q	=	distributed load [N/mm]
L	=	free span [mm]
E_b	=	flexural modulus [N/mm ²]
I	=	moment of inertia [mm ⁴]
$\sigma_{b,\text{kar}}$	=	characteristic bending strength [N/mm ²]
$\sigma_{\text{optr.}}$	=	occurring flexural stress [N/mm ²]
$\sigma_{\text{toel.}}$	=	allowable flexural stress [N/mm ²]
W	=	section modulus [mm ³]
γ_m	=	material reduction factor [-]
A_s	=	shear area [mm ²]
b_o	=	width of concentrated load [mm]
L_o	=	length of concentrated load [mm]
L_s	=	track width [mm]
D	=	occurring shear force [N]
τ_{kar}	=	characteristic shear strength [N/mm ²]
$\tau_{\text{optr.}}$	=	occurring shear stress [N/mm ²]
$\tau_{\text{toel.}}$	=	allowable shear stress [N/mm ²]
$D_{\text{kar},i}$	=	characteristic resistance to shear due to a concentrated load [N]
BGT	=	serviceability limit state
UGT	=	ultimate limit state

5 Verification of allowable span on 2 supports

5.1 Self-weight

This load case is not a determining load case and has not been considered further.

5.2 Distributed mobile load

BGT 2	$1/0,81 \times Q_f$
UGT 2	$1,20 \times 1/0,54 \times G + 1,35 \times 1/0,81 \times Q_f$

Plank width	0,236 m
Self-weight	0,358 kN/m ²
Distributed mobile load	5,0 kN/m ²
G	0,084 N/mm
Q _f	1,2 N/mm
Maximum span at L/200	1740 mm

q _{BGT2}	1,46 N/mm
q _{UGT2}	2,15 N/mm

The calculation uses the following situation:

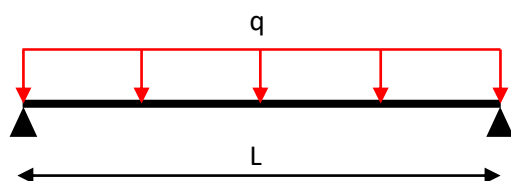

5.2.1 BGT 2

Verification of deflection:

$$y = \frac{5 \times q \times L^4}{384 \times EI} \leq \frac{L}{200}$$

q	1,46 N/mm
L	1740 mm
E	32130 N/mm ²
I	625197 mm ⁴
Y _{optr.}	8,66 mm
Y _{toel.}	8,70 mm
u.c.	0,99 OK

5.2.2 UGT 2

Verification of flexural stress:

$$\sigma_b = \frac{q \times L^2}{8 \times W} \leq \frac{\sigma_{b, kar}}{\gamma_m}$$

q	2,15 N/mm
L	1740 mm
W	26593 mm ³
$\sigma_{kar.}$	266 N/mm ²
γ_m	1,38 -
$\sigma_{optr.}$	31 N/mm ²
$\sigma_{toel.}$	193 N/mm ²
u.c.	0,16 OK

Verification of shear stress:

$$\tau = \frac{q \times L}{2 \times A_s} \leq \frac{\tau_{kar}}{\gamma_m}$$

q	2,15 N/mm
L	1740 mm
A_s	1052 mm ²
$\tau_{kar.}$	51,2 N/mm ²
γ_m	1,38 -
$\tau_{optr.}$	1,8 N/mm ²
$\tau_{toel.}$	37,1 N/mm ²
u.c.	0,05 OK

5.3 Concentrated load

BGT 3	$1/0,81 \times Qf;w$
UGT 3	$1,20 \times 1/0,54 \times G + 1,35 \times 1/0,81 \times Qf;w$

Plank width	0,236 m
Self-weight	0,358 kN/m ²
Concentrated load on 100 x 100 mm	7,0 kN
G	0,084 N/mm
Maximum span at L/100	1050 mm

Q_{BGT3}	8642 N
q_{UGT3}	0,188 N/mm
Q_{UGT3}	11667 N

The calculation uses the following situation:

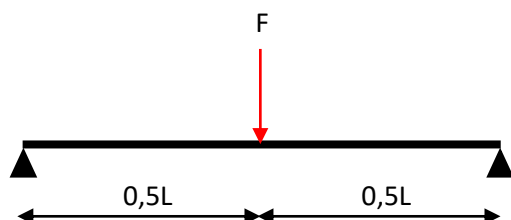

5.3.1 BGT 3

Verification of deflection:

$$y = \frac{F \times L^3}{48 \times EI} \leq \frac{L}{100}$$

F	8642 N
L	1050 mm
E	32130 N/mm ²
I	625197 mm ⁴
$y_{optr.}$	10,38 mm
$y_{toel.}$	10,50 mm
u.c.	0,99 OK

5.3.2 UGT 3

Verification of flexural stress:

$$\sigma_b = \frac{F \times L}{4 \times W} + \frac{q \times L^2}{8 \times W} \leq \frac{\sigma_{b, kar}}{\gamma_m}$$

F	11667 N
q	0,188 N/mm
L	1050 mm
W	26593 mm ³
σ_{kar}	266 N/mm ²
γ_m	1,38 -
σ_{optr}	116 N/mm ²
σ_{toel}	193 N/mm ²
u.c.	0,60 OK

Verification of shear force:

$$D_{optr.} = F \leq \frac{D_{kar,100}}{\gamma_m}$$

F	11667 N
$D_{kar,100}$	33658 N
γ_m	1,38 -
$D_{optr.}$	11111 N
$D_{toel.}$	24390 N
u.c.	0,46 OK

5.4 Service vehicle

BGT 4 $1/0,81 \times Qd$
UGT 4 $1,20 \times 1/0,54 \times G + 1,35 \times 1/0,81 \times Qd$

Plank width	0,236 m
Self-weight	0,358 kN/m ²
Concentrated load on 250 x250 mm	12,5 kN
G	0,084 N/mm
Track width	1750 mm
Maximum span situation 1 L/200	550 mm
Maximum span situation 2 L/200	N/A mm

Q_{BGT4}	15432 N
q_{UGT4}	0,188 N/mm
Q_{UGT4}	20833 N

The calculation uses the following situations:

Situation 1: multiple single spans

Situation 1 describes the situation where the vehicle can stand on multiple planks. These planks are on two supports. The single spans within the red rectangles are considered.

Vehicle position 1: $N/A L < L_s$

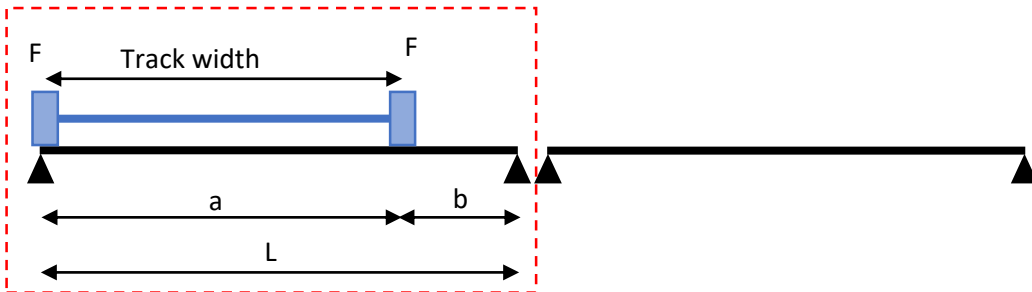

Vehicle position 2: $N/A L < L_s$

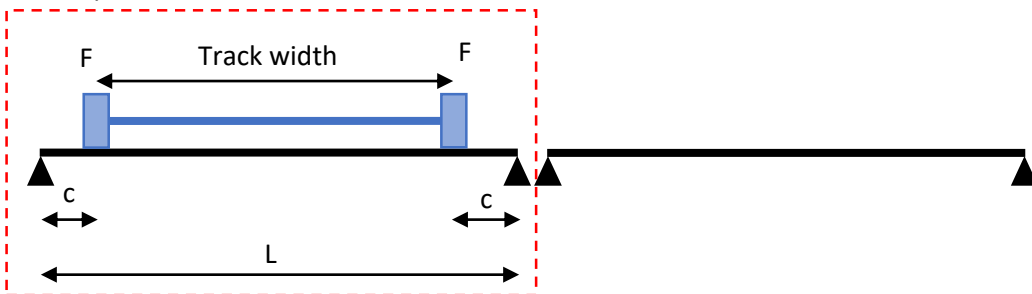

Vehicle position 3:

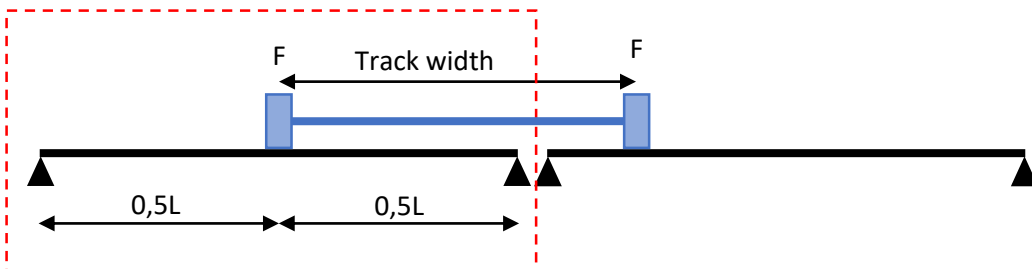

Situation 2: one single span $L > L_s$ N/A

Situation 2 describes the situation where one plank is equal to the entire width of the bridge. Two positions are considered here; these are shown below. The most critical position is reported, this depends on the total length L , track width L_s and the allowable deflection.

Vehicle position 1:

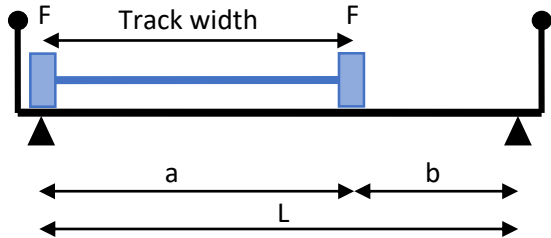

Vehicle position 2:

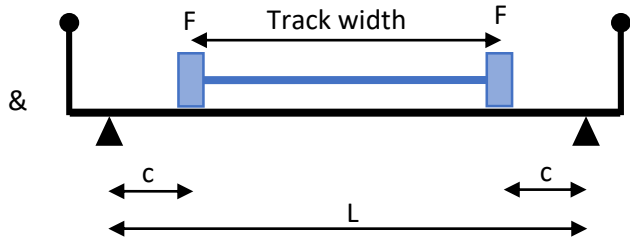

5.4.1 BGT 4 situation 1

Verification of deflection:

The maximum deflection for service vehicle position 2 is: $N/A \ L < L_s$

$$y_{pos2} = \frac{F \times c}{24 \times EI} \times (3L^2 - 4c^2) \leq \frac{L}{200}$$

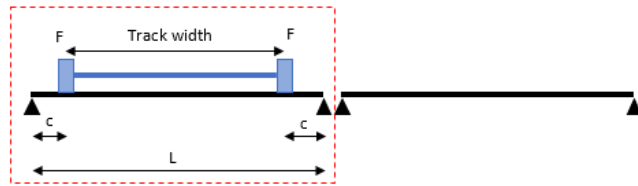

The maximum deflection for service vehicle position 3 is:

$$y_{pos3} = \frac{F \times L^3}{48 \times EI} \leq \frac{L}{200}$$

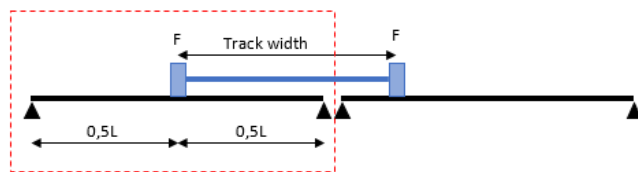

The maximum occurring deflection for situation 1:

F	15432 N
L	550 mm
c	0 mm
E	32130 N/mm ²
I	625197 mm ⁴
$y_{optr;pos2}$	N/A mm
$y_{optr;pos3}$	2,66 mm
$y_{optr;max}$	2,66 mm
$y_{toel.}$	2,75 mm
u.c.	0,97 OK

5.4.2 UGT 4 situation 1

Verification of flexural stress:

The maximum flexural stress for service vehicle position 2 is: $N/A L < L_s$

$$\sigma_{b;pos2} = \frac{F \times c}{W} + \frac{q \times L^2}{8 \times W} \leq \frac{\sigma_{b,kar}}{\gamma_m}$$

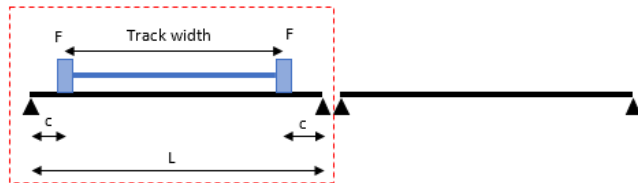

The maximum flexural stress for service vehicle position 3 is:

$$\sigma_{b;pos3} = \frac{F \times L}{4 \times W} + \frac{q \times L^2}{8 \times W} \leq \frac{\sigma_{b,kar}}{\gamma_m}$$

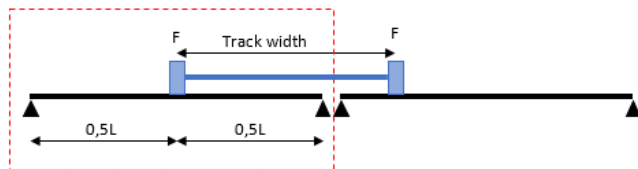

The maximum occurring flexural stress for situation 1:

F	20833 N
q	0,188 N/mm
L	550 mm
c	0 mm
W	26593 mm ³
$\sigma_{kar.}$	266 N/mm ²
γ_m	1,38 -
$\sigma_{optr;pos2}$	N/A N/mm ²
$\sigma_{optr;pos3}$	108 N/mm ²
$\sigma_{optr;max}$	108 N/mm ²
$\sigma_{toel.}$	193 N/mm ²
u.c.	0,56 OK

Verification of shear force:

$$D_{kar;250} > D_{kar;200}$$

$$D_{optr.} = \left(F \times \frac{L - \frac{1}{2} \times L_0}{L} \right) + \left(F \times \frac{b - \frac{1}{2} \times L_0}{L} \right) \leq \frac{D_{kar;250}}{\gamma_m}$$

The second term in the equation above is used only when $L > L_s + L_0$ (when the span is greater than the track width + wheel width). When $L < L_s + L_0$, the second term in the equation above is set equal to 0.

F	20833 N
L	550 mm
L ₀	250 mm
b	0 mm
D _{kar;250}	51886 N
γ _m	1,38 -
D _{optr.}	16098 N
D _{toel.}	37599 N
u.c.	0,43 OK

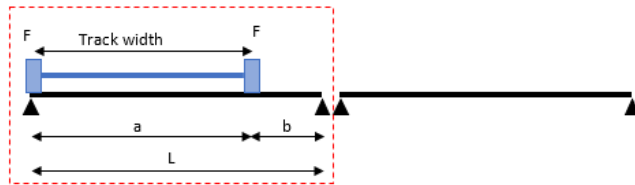

5.4.3 BGT 4 situation 2 N/A

Verification of deflection:

The maximum deflection for service vehicle position 1 is:

$$y_{pos1} = \frac{F \times a \times b}{27 \times EI \times L} \times (a + 2b) \times \sqrt{3a \times (a + 2b)} \leq \frac{L}{200}$$

Maximum deflection at: $x = \sqrt{\frac{a}{3}} \times (a + 2b)$ when $a > b$

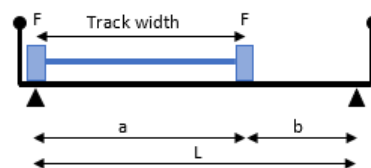

The maximum deflection for service vehicle position 2 is:

$$y_{pos2} = \frac{F \times c}{24 \times EI} \times (3L^2 - 4c^2) \leq \frac{L}{200}$$

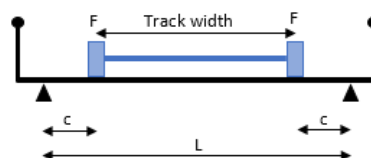

The maximum occurring deflection for situation 2:

F	15432 N
a	1750 mm
b	0 mm
c	0 mm
L	N/A mm
E	32130 N/mm ²
I	625197 mm ⁴
$y_{optr;pos1}$	N/A mm
$y_{optr;pos2}$	N/A mm
$y_{optr.max}$	N/A mm
$y_{toel.}$	0,05 mm
u.c.	N/A

5.4.4 UGT 4 situation 2 N/A

Verification of flexural stress:

The maximum flexural stress for service vehicle position 1 is:

$$\sigma_{b;pos1} = \frac{F \times a \times b}{L \times W} + \frac{q \times L^2}{8 \times W} \leq \frac{\sigma_{b,kar}}{\gamma_m}$$

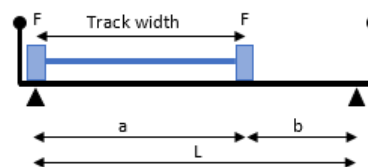

The maximum flexural stress for service vehicle position 2 is:

$$\sigma_{b;pos2} = \frac{F \times c}{W} + \frac{q \times L^2}{8 \times W} \leq \frac{\sigma_{b,kar}}{\gamma_m}$$

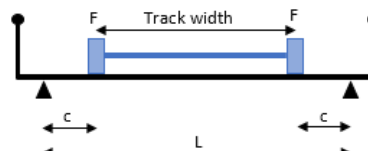

The maximum occurring flexural stress for situation 2:

F	20833 N
q	0,188 N/mm
a	1750 mm
b	0 mm
c	0 mm
L	N/A mm
W	26593 mm ³
σ _{kar.}	266 N/mm ²
γ _m	1,38 -
σ _{optr.pos1}	N/A N/mm ²
σ _{optr.pos2}	N/A N/mm ²
σ _{optr.max}	N/A N/mm ²
σ _{toel.}	193 N/mm ²
u.c.	N/A

Verification of shear force:

$$D_{kar;250} > D_{kar;200}$$

$$D_{optr.} = \left(F \times \frac{L - \frac{1}{2} \times L_0}{L} \right) + \left(F \times \frac{b - \frac{1}{2} \times L_0}{L} \right) \leq \frac{D_{kar,250}}{\gamma_m}$$

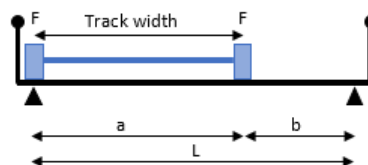

F	20833 N
L	N/A mm
L ₀	250 mm
b	0 mm
D _{kar;250}	51886 N
γ _m	1,38 -
D _{optr.}	N/A N
D _{toel.}	37599 N
u.c.	N/A

5.5 Snow

The maximum allowable span is limited to 5000 mm.

$$\text{UGT 5} \quad 1,20 \times 1/0,54 \times G + 1,50 \times 1/0,65 \times Q_s$$

Plank width	0,236 m
Self-weight	0,358 kN/m ²
Distributed load	1,4 kN/m ²
G	0,084 N/mm
Q _f	0,3 N/mm
Maximum span	5000 mm

$$q_{\text{UGT5}} \quad 1,56 \text{ N/mm}$$

The calculation uses the following situation:

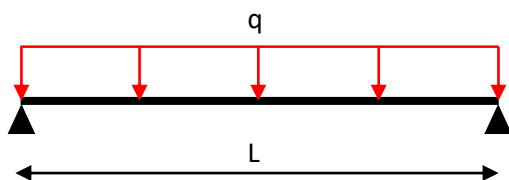

5.5.1 UGT 5

Verification of flexural stress:

$$\sigma_b = \frac{q \times L^2}{8 \times W} \leq \frac{\sigma_{b, kar}}{\gamma_m}$$

q	1,56 N/mm
L	5000 mm
W	26593 mm ³
σ _{kar.}	266 N/mm ²
γ _m	1,38 -
σ _{optr.}	183 N/mm ²
σ _{toel.}	193 N/mm ²
u. c.	0,95 OK

Verification of shear stress:

$$\tau = \frac{q \times L}{2 \times A_s} \leq \frac{\tau_{kar}}{\gamma_m}$$

q	1,56 N/mm
L	5000 mm
A _s	1052 mm ²
τ _{kar.}	51,2 N/mm ²
γ _m	1,38 -
τ _{optr.}	1,3 N/mm ²
τ _{toel.}	37,1 N/mm ²
u.c.	0,04 OK

5.6 Accidental vehicle

UGT 6 **1,20 x 1/0,54 x G + 1,35 x 1/0,81 x Aov**

Plank width	0,236 m
Self-weight	0,358 kN/m ²
Concentrated load on 200 x 200 mm	40,0 kN
G	0,084 N/mm
Track width	1300 mm
Maximum span situation 1	220 mm
Maximum span situation 2	N/A mm

q_{UGT6} 0,188 N/mm

Q_{UGT6} 66667 N

The calculation uses the following situations:

Situation 1: multiple single spans

Situation 1 describes the situation where the vehicle can stand on multiple planks. These planks are on two supports. The single spans within the red rectangles are considered.

Vehicle position 1: $N/A L < L_s$

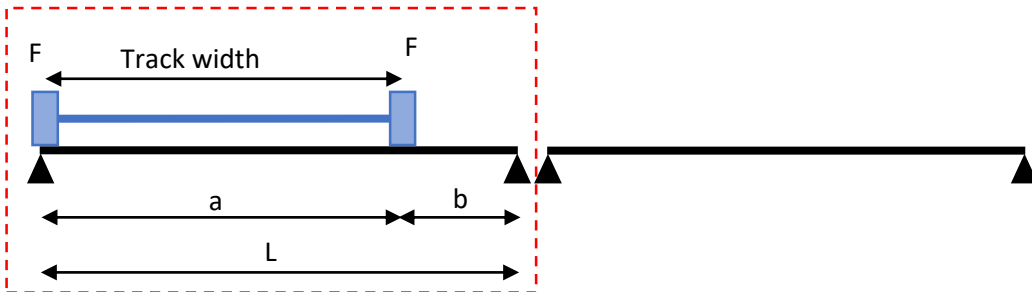

Vehicle position 2: $N/A L < L_s$

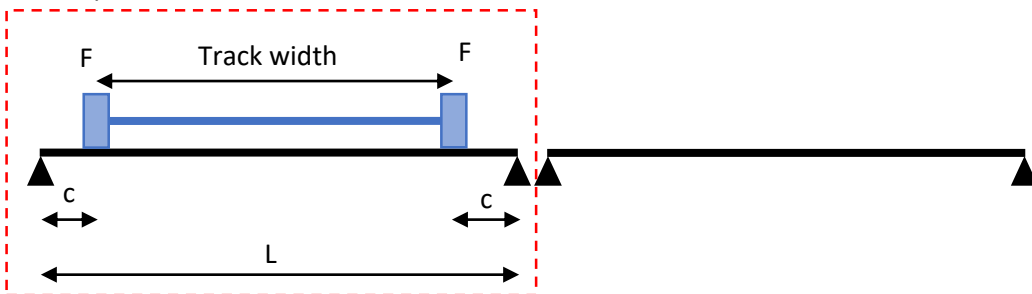

Vehicle position 3:

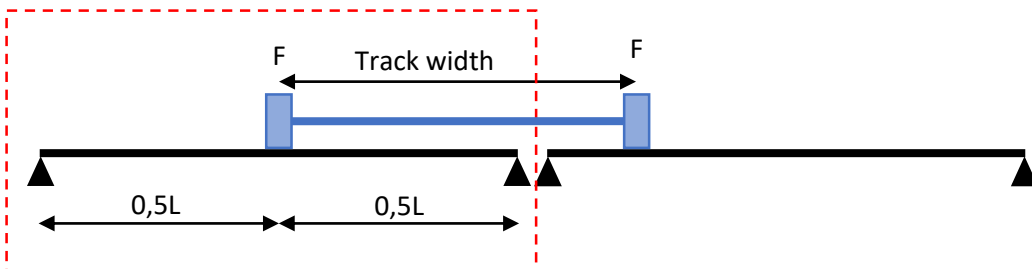

Situation 2: one single span $L > L_s$ N/A

Situation 2 describes the situation where one plank is equal to the entire width of the bridge. Two positions are considered here; these are shown below. The most critical position is reported, this depends on the total length L , track width L_s and the allowable deflection.

Vehicle position 1:

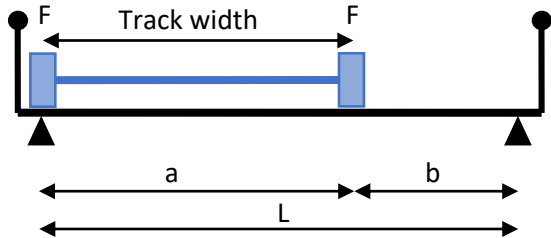

Vehicle position 2:

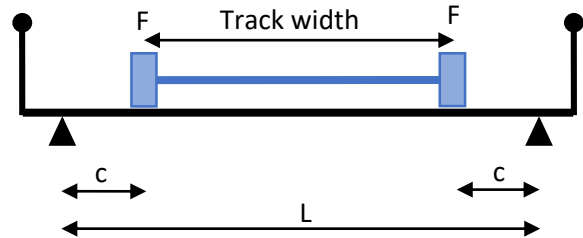

5.6.1 UGT 6 situation 1

Verification of flexural stress:

The maximum flexural stress for accidental vehicle position 2 is: **N/A** $L < L_s$

$$\sigma_{b;pos2} = \frac{F \times c}{W} + \frac{q \times L^2}{8 \times W} \leq \frac{\sigma_{b,kar}}{\gamma_m}$$

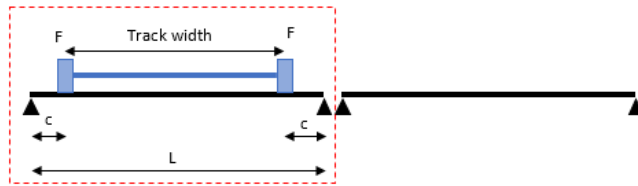

The maximum flexural stress for service vehicle position 3 is:

$$\sigma_{b;pos3} = \frac{F \times L}{4 \times W} + \frac{q \times L^2}{8 \times W} \leq \frac{\sigma_{b,kar}}{\gamma_m}$$

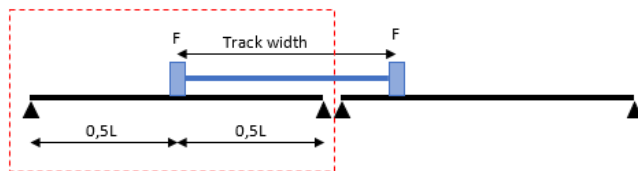

The maximum occurring flexural stress for situation 1:

F	66667 N
q	0,188 N/mm
L	220 mm
c	0 mm
W	26593 mm ³
$\sigma_{kar.}$	266 N/mm ²
γ_m	1,38 -
$\sigma_{optr;pos2}$	N/A N/mm ²
$\sigma_{optr;pos3}$	138 N/mm ²
$\sigma_{optr,max}$	138 N/mm ²
$\sigma_{toel.}$	193 N/mm ²
u.c.	0,72 OK

Verification of shear force:

$$D_{optr.} = \left(F \times \frac{L - \frac{1}{2} \times L_0}{L} \right) + \left(F \times \frac{b - \frac{1}{2} \times L_0}{L} \right) \leq \frac{D_{kar;200}}{\gamma_m}$$

F	66667 N
L	220 mm
L ₀	200 mm
D _{kar;200}	51886 N
γ _m	1,38 -
D _{optr.}	36364 N
D _{toel.}	37599 N
u.c.	0,97 OK

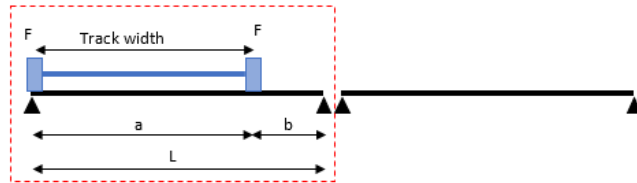

5.6.2 UGT 6 situation 2 **N/A**

Verification of flexural stress:

The maximum flexural stress for accidental vehicle position 1 is:

$$\sigma_{b;pos1} = \frac{F \times a \times b}{L \times W} + \frac{q \times L^2}{8 \times W} \leq \frac{\sigma_{b,kar}}{\gamma_m}$$

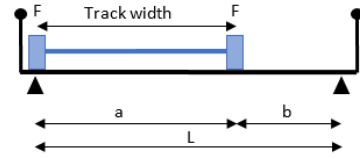

The maximum flexural stress for accidental vehicle position 2 is:

$$\sigma_{b;pos2} = \frac{F \times c}{W} + \frac{q \times L^2}{8 \times W} \leq \frac{\sigma_{b,kar}}{\gamma_m}$$

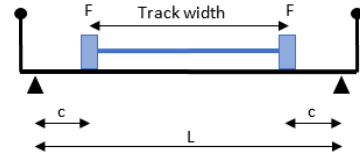

The maximum occurring flexural stress for situation 2:

F	66667 N
q	0,188 N/mm
a	1300 mm
b	0 mm
c	0 mm
L	N/A mm
W	26593 mm ³
$\sigma_{kar.}$	266 N/mm ²
γ_m	1,38 -
$\sigma_{optr.pos1}$	N/A N/mm ²
$\sigma_{optr.pos2}$	N/A N/mm ²
$\sigma_{optr.max}$	N/A N/mm ²
$\sigma_{toel.}$	193 N/mm ²
u.c.	N/A

Verification of shear force:

$$D_{optr.} = \left(F \times \frac{L - \frac{1}{2} \times L_0}{L} \right) + \left(F \times \frac{b - \frac{1}{2} \times L_0}{L} \right) \leq \frac{D_{kar,200}}{\gamma_m}$$

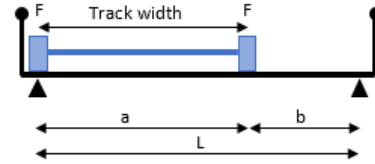

F	66667 N
L	N/A mm
L ₀	200 mm
b	0 mm
D _{kar,200}	51886 N
γ _m	1,38 -
D _{optr.}	N/A N
D _{toel.}	37599 N
u.c.	N/A

5.7 Summary

The plank has been verified for each load case. The maximum span was determined using the aforementioned strength requirements and deflection requirements up to $L/550$. For each case, the maximum span is shown in figure 6 and figure 7.

Unless otherwise stated, the calculation was made for a simply supported beam on two supports.

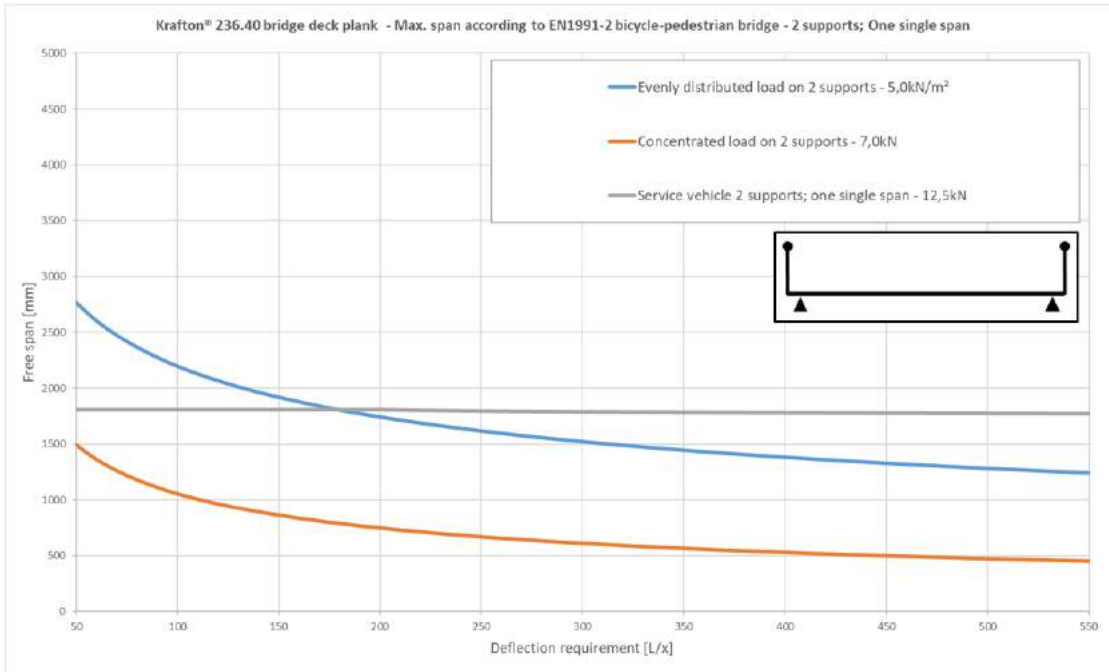

figure 6: Maximum span as a function of deflection requirements; 2 supports; multiple single spans

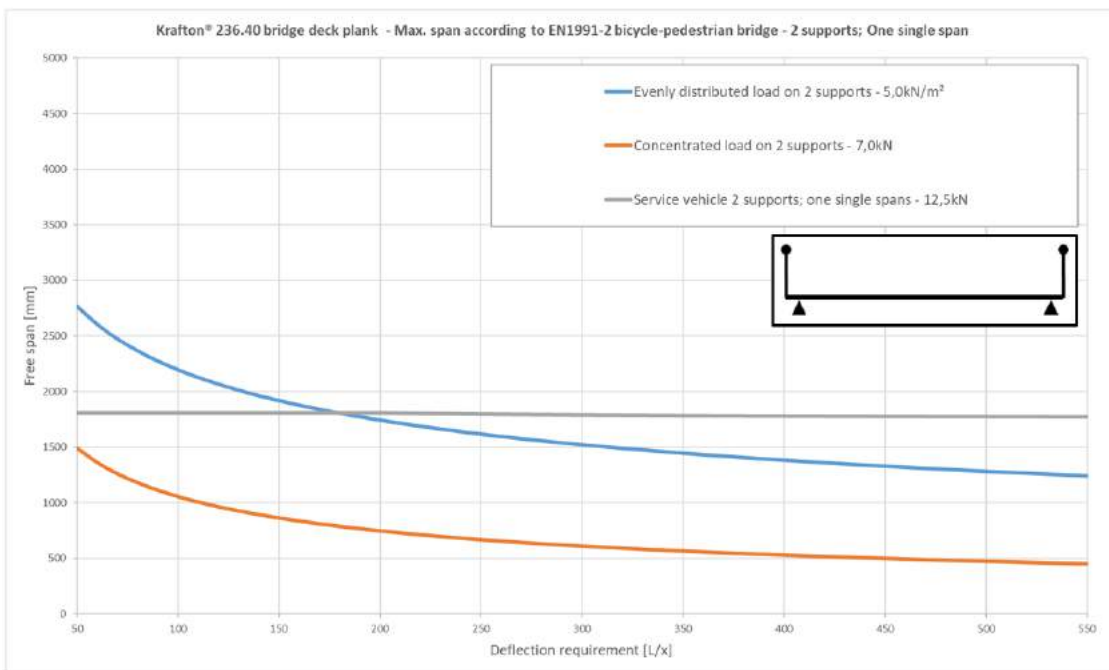

figure 7: Maximum span as a function of deflection requirements; 2 supports; one single span

The spans were calculated with the following loads:

- Evenly distributed load 5,0 kN/m²
- Concentrated load 7,0 kN
- Service vehicle 50 kN
- Accidental vehicle 120 kN

Note:

A minimum deflection requirement of $L/200$ has been considered for the service vehicle

6 Verification of allowable span on 3 or more supports

6.1 Self-weight

This load case is not a determining load case and has not been considered further.

6.2 Distributed mobile load

BGT 2	$1/0,81 \times Q_f$
UGT 2	$1,20 \times 1/0,54 \times G + 1,35 \times 1/0,81 \times Q_f$

Plank width	0,236 m
Self-weight	0,358 kN/m ²
Distributed load	5,0 kN/m ²
G	0,084 N/mm
Q _f	1,2 N/mm
Maximum span L/200	2330 mm

q _{BGT2}	1,46 N/mm
q _{UGT2}	2,15 N/mm

The calculation uses the following situation:

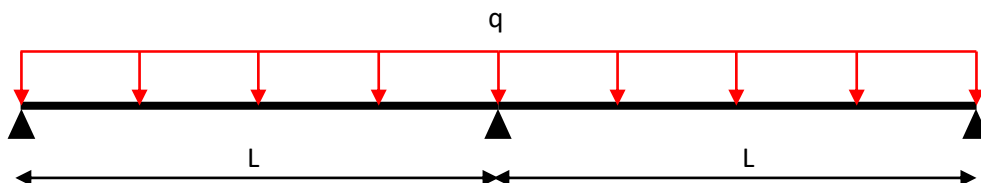

6.2.1 BGT 2

Verification of deflection:

$$y = \frac{q \times L^4}{185 \times EI} \leq \frac{L}{200}$$

q	1,46 N/mm
L	2330 mm
E	32130 N/mm ²
I	625197 mm ⁴
Y _{optr.}	11,55 mm
Y _{toel.}	11,65 mm
u.c.	0,99 OK

6.2.2 UGT 2

Strength verification is conservatively simplified to a single span situation.

Verification of flexural stress:

$$\sigma_b = \frac{q \times L^2}{8 \times W} \leq \frac{\sigma_{b, kar}}{\gamma_m}$$

q	2,15 N/mm
L	2330 mm
W	26593 mm ³
$\sigma_{kar.}$	266 N/mm ²
γ_m	1,38 -
$\sigma_{optr.}$	55 N/mm ²
$\sigma_{toel.}$	193 N/mm ²
u.c.	0,29 OK

Verification of shear stress:

$$\tau = \frac{q \times L}{2 \times A_s} \leq \frac{\tau_{kar}}{\gamma_m}$$

q	2,15 N/mm
L	2330 mm
A_s	1052 mm ²
$\tau_{kar.}$	51,2 N/mm ²
γ_m	1,38 -
$\tau_{optr.}$	2,4 N/mm ²
$\tau_{toel.}$	37,1 N/mm ²
u.c.	0,06 OK

6.3 Concentrated load

BGT 3 $1/0,81 \times Qf;w$
UGT 3 $1,20 \times 1/0,54 \times G + 1,35 \times 1/0,81 \times Qf;w$

Plank width	0,236 m
Self-weight	0,358 kN/m ²
Concentrated load on 100 x 100 mm	7,0 kN
G	0,084 N/mm
Maximum span L/100	1240 mm

Q_{BGT3}	8642 N
q_{UGT3}	0,188 N/mm
Q_{UGT3}	11667 N

The calculation uses the following situation:

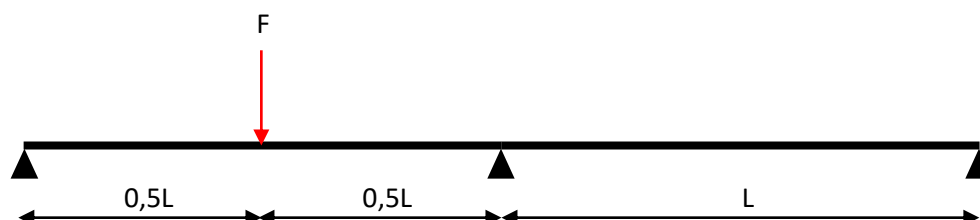

6.3.1 BGT 3

Verification of deflection:

Deflection at $x=0.5L$ is representative for the maximum deflection⁵.

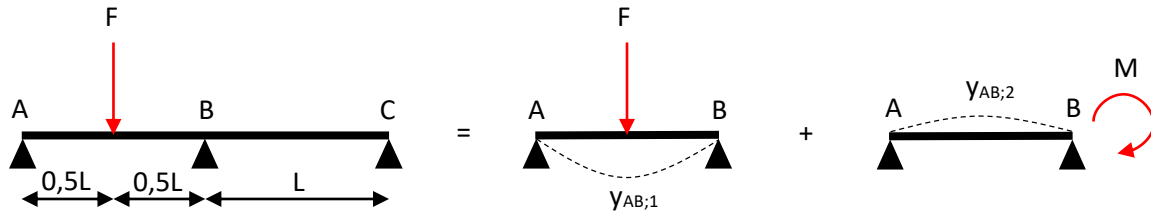

$$y_{AB} = \frac{F \times L^3}{48 \times EI} + \frac{M}{6 \times EI} \left(-\frac{3}{8} L^2 \right)$$

$$M = \frac{3 \times F \times L}{32}$$

$$y = \frac{23 \times F \times L^3}{1536 \times EI} < \frac{L}{100}$$

F	8642 N
L	1240 mm
E	32130 N/mm ²
I	625197 mm ⁴
$y_{optr.}$	12,28 mm
$y_{toel.}$	12,40 mm
u.c.	0,99 OK

⁵ In reality, the location of maximum deflection is not at $x=0.5L$. This assumption introduces a maximum error of 2%. Considering deflection has no effect on safety, this simplification is acceptable.

6.3.2 UGT 3

Strength verification is conservatively simplified to a single span situation.

Verification of flexural stress:

$$\sigma_b = \frac{F \times L}{4 \times W} + \frac{q \times L^2}{8 \times W} \leq \frac{\sigma_{b, kar}}{\gamma_m}$$

F	11667 N
q	0,188 N/mm
L	1240 mm
W	26593 mm ³
σ_{kar}	266 N/mm ²
γ_m	1,38 -
$\sigma_{optr.}$	137 N/mm ²
$\sigma_{toel.}$	193 N/mm ²
u.c.	0,71 OK

Verification of shear stress:

$$D_{optr.} = F \leq \frac{D_{kar,100}}{\gamma_m}$$

F	11667 N
$D_{kar,100}$	33658 N
γ_m	1,38 -
$D_{optr.}$	11111 N
$D_{toel.}$	24390 N
u.c.	0,46 OK

6.4 Service vehicle

BGT 4 $1/0,81 \times Q_d$
UGT 4 $1,20 \times 1/0,54 \times G + 1,35 \times 1/0,81 \times Q_d$

Plank width	0,236 m
Self-weight	0,358 kN/m ²
Concentrated load on 250 x 250 mm	12,5 kN
G	0,084 N/mm
Track width	1750 mm
Maximum span L/200	650 mm

Q_{BGT4}	15432 N
q_{UGT4}	0,188 N/mm
Q_{UGT4}	20833 N

The calculation uses the following situations:

Situation 1:

Vehicle position 1:

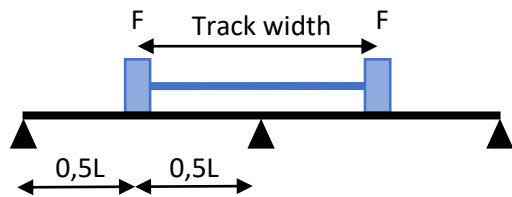

Vehicle position 2:

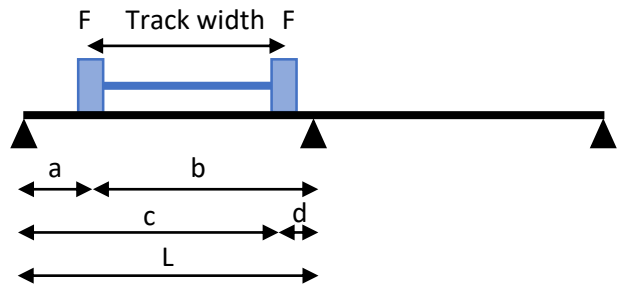

Situation 2:

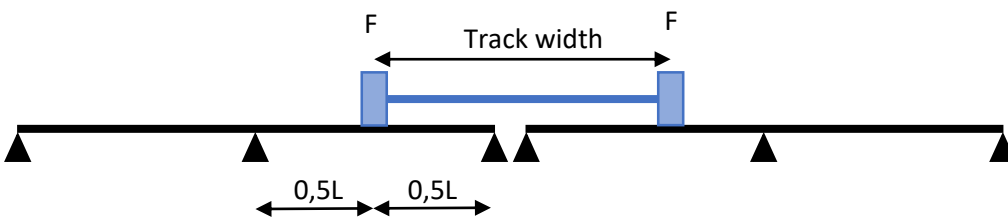

6.4.1 BGT 4

Verification of deflection:

The maximum deflection for service vehicle situation 1 is:

Deflection at $x=0.5L$ is representative for the maximum deflection⁶.

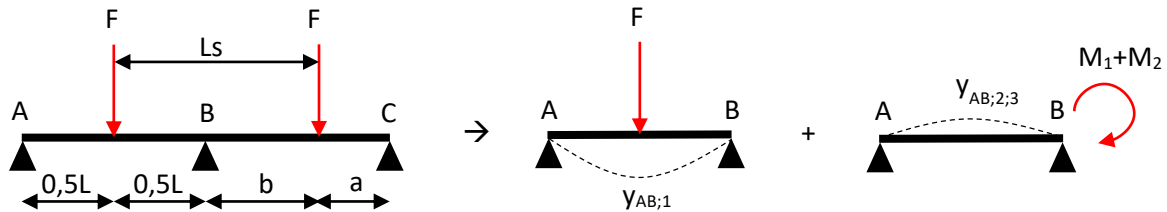

$$y_{pos1} = \frac{F \times L^3}{48 \times EI} + \frac{M_1}{6 \times EI} \left(-\frac{3}{8} L^2 \right) + \frac{M_2}{6 \times EI} \left(-\frac{3}{8} L^2 \right) \leq \frac{L}{200}$$

$$M_1 = \frac{3 \times F \times L}{32} \quad M_2 = \frac{F \times a \times b}{4L^2} \times (L + a) \quad a = \frac{3}{2}L - L_s \quad b = L - a$$

$$y_{pos1} = \frac{F \times L^3}{48 \times EI} - \frac{3 \times F \times L^3}{512 \times EI} - \frac{M_2 \times L^2}{16 \times EI} \leq \frac{L}{200}$$

M_2 is only available when $a > 0$, or $L > 2/3L_s$. In the situation where $a < 0$ is true, F in M_2 is considered to be 0kN.

⁶ In reality, the location of maximum deflection is not at $x=0.5L$. This assumption introduces a maximum error of 2%. Considering deflection has no effect on safety, this simplification is acceptable.

The maximum deflection for service vehicle situation 1 position 2 is: **N/A** $L < L_s$

This calculation is conservatively simplified to a single span.

$$y_{pos2} = \frac{F \times c}{24 \times EI} \times (3L^2 - 4c^2) \leq \frac{L}{200}$$

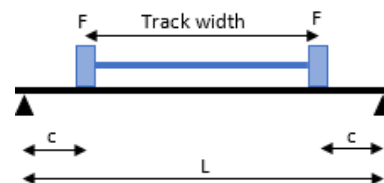

The maximum occurring deflection for situation 1:

F	15432 N
L	650 mm
L _s	1750 mm
a	-775 mm
b	1425 mm
c	0 mm
E	32130 N/mm ²
I	625197 mm ⁴
Y _{optr.pos1}	3,16 mm
Y _{optr.pos2}	N/A mm
Y _{optr.max}	3,16 mm
Y _{toel.}	3,25 mm
u.c.	0,97 OK

To verify deflection, situation 2 **DEFLECTS MORE** than situation 1, it is infrequent and therefore not considered. Should it be required, a separate analysis should be conducted.

6.4.2 UGT 4

Strength verification is conservatively simplified to a single span and applies to all considered situations.

Verification of flexural stress:

The maximum flexural stress for service vehicle position 1 is:

$$\sigma_b = \frac{F \times L}{4 \times W} + \frac{q \times L^2}{8 \times W} \leq \frac{\sigma_{b, kar}}{\gamma_m}$$

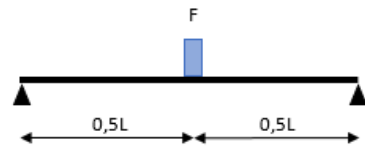

The maximum flexural stress for service vehicle position 2 is: **N/A** $L < L_s$

$$\sigma_b = \frac{2 \times F \times L}{4 \times W} + \frac{q \times L^2}{8 \times W} \leq \frac{\sigma_{b, kar}}{\gamma_m}$$

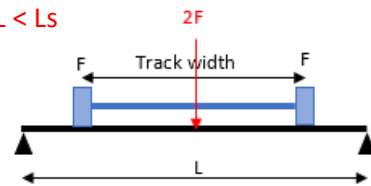

Both concentrated loads are conservatively merged to one concentrated load. This position occurs only if: track width > L

The maximum occurring flexural stress:

F	20833 N
q	0,188 N/mm
L	650 mm
W	26593 mm ³
$\sigma_{kar.}$	266 N/mm ²
γ_m	1,38 -
$\sigma_{optr. pos1}$	128 N/mm ²
$\sigma_{optr. pos2}$	N/A N/mm ²
$\sigma_{optr. max}$	128 N/mm ²
$\sigma_{toel.}$	193 N/mm ²
u.c.	0,66 OK

Verification of shear force:

$$D_{250} > D_{200}$$

$$D_{optr.} = \left(F \times \frac{L - \frac{1}{2} \times L_0}{L} \right) + \left(F \times \frac{b - \frac{1}{2} \times L_0}{L} \right) \leq \frac{D_{kar;250}}{\gamma_m}$$

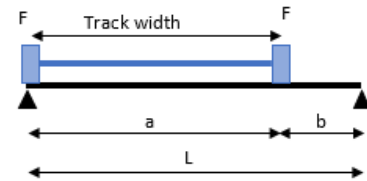

F	20833 N
L	650 mm
b	0 mm
L_0	250 mm
$D_{kar;250}$	51886 N
γ_m	1,38 -
$D_{optr.}$	16827 N
$D_{toel.}$	37599 N
u.c.	0,45 OK

6.5 Snow

Strength verification is conservatively simplified to a single span. Verification is described in the single span chapter of this report. Chapter 5.5.

6.6 Accidental vehicle

UGT 6 $1,20 \times 1/0,54 \times G + 1,35 \times 1/0,81 \times Aov$

Plank width	0,236 m
Self-weight	0,358 kN/m ²
Concentrated load on 200 x 200 mm	40,0 kN
G	0,084 N/mm
Track width	1300 mm
Maximum span	220 mm

q_{UGT6}	0,188 N/mm
Q_{UGT6}	66667 N

The calculation uses the following situations:

Situation 1:

Vehicle position 1:

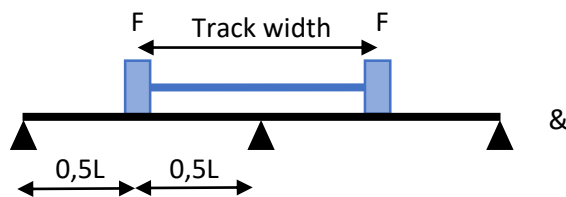

Vehicle position 2: $N/A \ L < L_s$

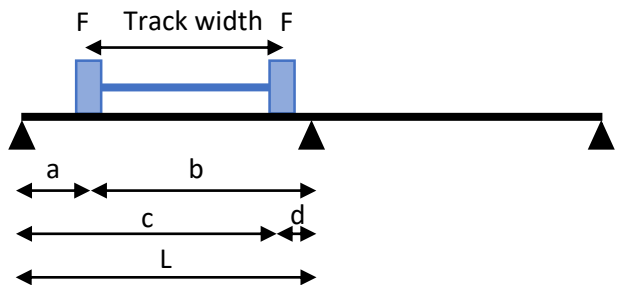

Situation 2:

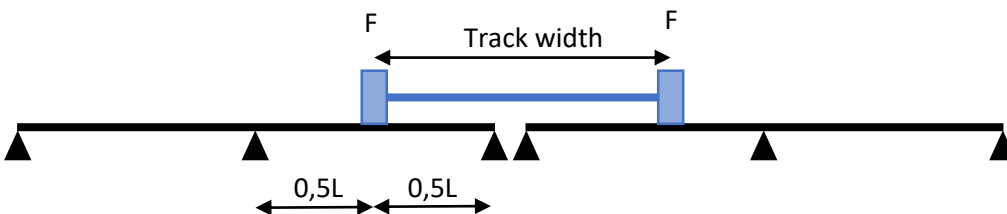

6.6.1 UGT 6

Verification of flexural stress:

The maximum flexural stress for the accidental vehicle situation 1 position 1 is more favourable than situation 2 and is therefore not considered.

The maximum flexural stress for accidental vehicle situation 1 position 2 is: $N/A L < L_s$

$$\sigma_b = \sigma_{b;1} + \sigma_{b;2} + \sigma_{b;3} \leq \frac{\sigma_{b,kar}}{\gamma_m}$$

Flexural stress at location as a result of wheel 1:

$$\sigma_{b;1} = \frac{F \times a \times b}{4 \times L^2 \times W} \times (4 \times L^2 - a \times (L + a))$$

Flexural stress at location as a result of wheel 2:

$$\sigma_{b;2} = \frac{F \times c \times d}{4 \times L^2 \times W} \times (4 \times L^2 - c \times (L + c)) \times \frac{c - L_s}{c}$$

Flexural stress at location as a result of self-weight:

$$\sigma_{b;3} = \frac{3 \times q \times L \times a - 4 \times q \times a^2}{8 \times W}$$

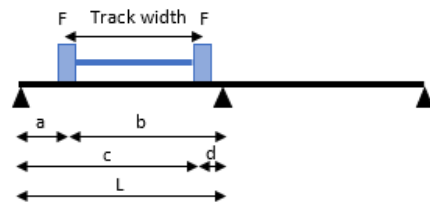

$$\sigma_b = \sigma_{b;1} + \sigma_{b;2} + \sigma_{b;3} \leq \frac{\sigma_{b,kar}}{\gamma_m}$$

F	66667 N
q	0,188 N/mm
L	220 mm
Ls	1300 mm
a	110 mm
b	110 mm
c	0 mm
d	0 mm
W	26593 mm ³
$\sigma_{kar.}$	266 N/mm ²
γ_m	1,38 -
$\sigma_{b;1}$	N/A N/mm ²
$\sigma_{b;2}$	N/A N/mm ²
$\sigma_{b;3}$	N/A N/mm ²
$\sigma_{optr.}$	N/A N/mm ²
$\sigma_{toel.}$	193 N/mm ²
u.c.	N/A

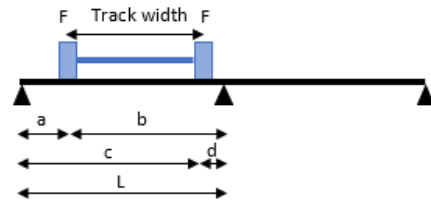

The maximum flexural stress for accidental vehicle situation 2 is:

The flexural stress at $x=0.5L$ is representative of the maximum flexural stress⁷.

$$\sigma_b = \frac{13 \times F \times L}{64 \times W} + \frac{q \times L^2}{16 \times W}$$

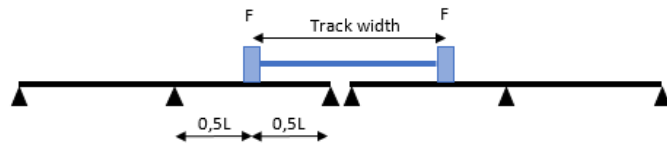

F	66667 N
q	0,188 N/mm
L	220 mm
W	26593 mm ³
$\sigma_{kar.}$	266 N/mm ²
γ_m	1,38 -
$\sigma_{optr.}$	112 N/mm ²
$\sigma_{toel.}$	193 N/mm ²
u.c.	0,58 OK

⁷ In reality, the location of maximum flexural stress is not at $x=0.5L$. This assumption introduces an error of 2%. To compensate for this margin of error, a maximum u.c. of 0.98 is allowed.

Verification of shear force:

Shear verification is conservatively simplified to a single span.

$$D_{optr.} = \left(F \times \frac{L - \frac{1}{2} \times L_0}{L} \right) + \left(F \times \frac{b - \frac{1}{2} \times L_0}{L} \right) \leq \frac{D_{kar;200}}{\gamma_m}$$

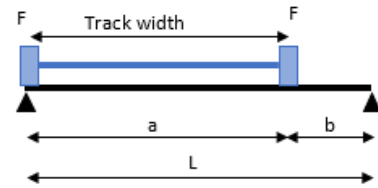

F	66667 N
L	220 mm
b	0 mm
L ₀	200 mm
D _{kar;200}	51886 N
γ _m	1,38 -
D _{optr.}	36364 N
D _{toel.}	37599 N
u.c.	0,97 OK

6.7 Summary

The plank has been verified for each load case. The maximum span was determined using the aforementioned strength requirements and deflection requirements up to $L/550$. For each case, the maximum span is shown in figure 8.

Unless otherwise stated, the calculation was made for a continuous beam on three supports.

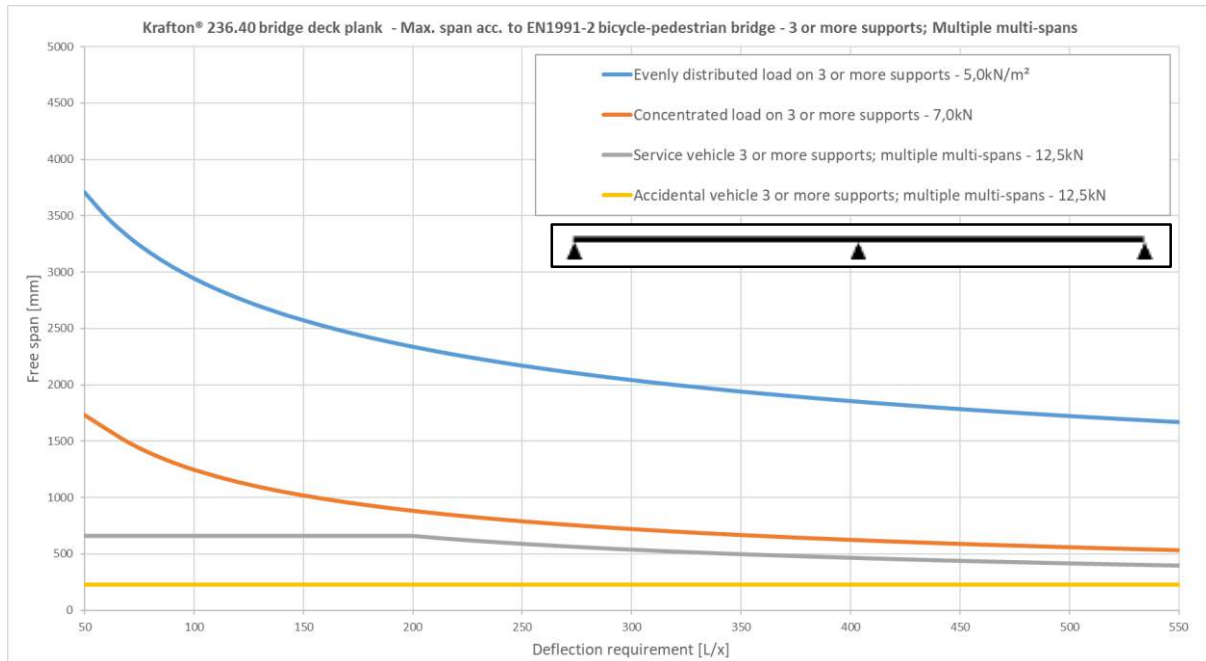

figure 8: Maximum span as a function of deflection requirements; 3 or more supports

The spans were calculated with the following loads:

- Evenly distributed load 5,0 kN/m²
- Concentrated load 7,0 kN
- Service vehicle 50 kN
- Accidental vehicle 120 kN

Note:

- A minimum deflection requirement of $L/200$ has been considered for the service vehicle
- Deflection analysis for service vehicles on multi-span planks is according to situation 1, as per figure 9. In case situation 2 can occur, an additional analysis needs to be performed.

Serviceability Limit State (BGT)

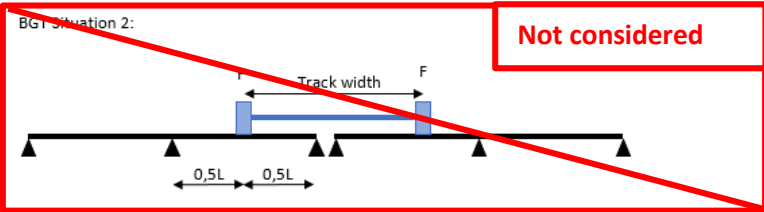
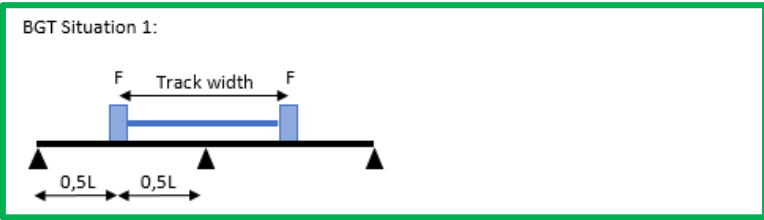

Ultimate Limit State (UGT)

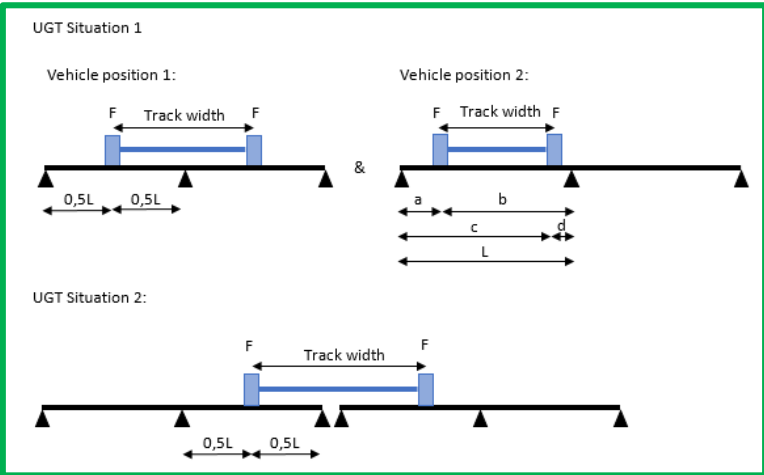

figure 9: Considered situations service- and accidental vehicle multi-span BGT and UGT

7 Comfort

$$f = \frac{1}{2\pi} * C * \sqrt{\frac{EI * g}{h_c * q * L^4}}$$

$$f \geq 5 \text{ Hz}$$

Plank width	w	0,236 mm
Self-weight	q	0,358 N/mm
Gravitational acceleration	g	9,81 m/s ²
Free span	L	3600 mm
Flexural stiffness	EI	2,01E+10 Nmm ²
Conversion factor comfort	h _c	0,81 -
Factor for support	C	9,87 -
	f _{optr.}	5,27 Hz
	f _{toel.}	5,00 Hz
	u.c.	0,95 OK

The maximum span of the plank at the 5Hz limit is 3600 mm, which is higher than the maximum spans in the other load situations.

The comfort requirement does not determine the maximum allowable span.

8 Conclusion

The krafton® 236.40 mm bridge deck plank complies with the Eurocode when a span and deflection requirement is chosen according to the charts shown.

For questions or special applications, please contact:

krafton®

Markweg Zuid 34

4794 SN Heijningen

T +31 (0) 168227510

E / info@krafton.nl

Appendix A: Properties of the bridge deck plank

A.1 Summary

This appendix reports the mechanical properties of the pultruded glass fibre reinforced krafton® 236.40 bridge deck plank. The mechanical properties of the bridge deck plank were determined through testing. The properties are summarised in table 3.

table 3: Mechanical properties

		Unit	Krafton® 236.40
Dimensions	(b x h)	mm	236 x 40
Surface	(A)	mm ²	2986
Shear area	(A _s)	mm ²	1052
Moment of inertia	(I)	mm ⁴	625197
Section modulus	(W)	mm ³	26593
Weight	(G)	kg/m ²	22,8
Modulus of elasticity	(E _{gem})	N/mm ²	32130
Flexural stress	(σ _{b,kar})	N/mm ²	266
Shear stress	(τ _{kar})	N/mm ²	51,2
Profile properties			
Flexural stiffness	(EI)	Nmm ² /mm	8,51E+07
Flexural strength	(M _b)	Nmm/mm	29947
Shear strength	(D)	N/mm	228
Shear force on 100x100mm	(D _{kar,100})	N	33658
Shear force on 200x200mm	(D _{kar,200})	N	51886

A.2 Tests

A.2.1 Description of tests

The following tests were carried out:

- Determination of flexural stiffness and flexural strength according to EN ISO 14125
- Determination of shear strength by means of a 3-point bending test with line load immediately adjacent to the support.
- Determination of allowable shear force due to a concentrated load of 200mm x 200mm corresponding to the wheel print of an accidental vehicle according to EN1991-2 NB – Traffic loads on bridges.
- Determination of allowable shear force due to a concentrated load of 100mm x 100mm

A.3 Test results

According to EN1990:2002 appendix D, the characteristic strength value is calculated from the average strength value minus k_n times the standard deviation.

The values for k_n are used according to table D1 in EN1990:2002.

The characteristic stiffness value is equal to the average measured stiffness value.

table 4 EN1990:2002 appendix D Table D1

Tabel D1 — Waarden van k_n voor de 5 % karakteristieke waarde

n	1	2	3	4	5	6	8	10	20	30	∞
V_x bekend	2,31	2,01	1,89	1,83	1,80	1,77	1,74	1,72	1,68	1,67	1,64
V_x niet bekend	–	–	3,37	2,63	2,33	2,18	2,00	1,92	1,76	1,73	1,64

A.3.1 Flexural modulus

The mechanical properties were tested by krafton®, the tests were performed on 22-10-2018.

The flexural modulus was determined by determining the slope of the force-displacement curve. The slope was determined by taking two points on the graph and drawing a line between them. The points were chosen in the linear part of the curve. The E-modulus is calculated using the following formula:

$$\Delta y = \frac{\Delta F \times L^3}{48 \times E_b I} \quad \rightarrow \quad E_b = \frac{\Delta F \times L^3}{48 \times I \times \Delta y}$$

Wherin:

- Δy = Displacement [mm]
- ΔF = Force [N]
- L = Span [mm]
- E_b = Flexural modulus [N/mm²]
- I = Moment of inertia [mm⁴]

table 5: Test results flexural modulus

Sample nr.	L [mm]	ΔF [N]	Δy [mm]	E_b [N/mm ²]
1	1200	39590	71,72	31786
2	1200	40740	72,61	32308
3	1200	41950	75,02	32199
4	1200	42390	76,22	32024
5	1200	41510	74,15	32235
6	1200	41750	74,60	32226
7				
Average value [$E_{b, gem}$]				32130

A.3.2 Flexural strength single span

The flexural strength is determined based on the test performed by krafton® on 22-10-2018.

The test values ($F_{failure}$) are used to determine the flexural strength (σ_b) using the following formula:

$$\sigma_b = \frac{F_{failure} \times L}{4 \times W}$$

Wherein L = span see table 6
W = section modulus 26593 mm³

table 6: Test results flexural strength single span

Sample nr.	L [mm]	F _{failure} [N]	σ _{b,min} [N/mm ²]
1	1200	39590	447
2	1200	40740	460
3	1200	41950	473
4	1200	42390	478
5	1200	41510	468
6	1200	41750	471
Average [σ _{b,gem.}]			466
Standard deviation [s]			11
Characteristic value [σ _{b,kar.}]			441

The characteristic value is determined from the average value minus 2,18 x the standard deviation.

A.3.3 Flexural strength multi-span

The flexural strength is determined based on the test performed by krafton® on 22-10-2018.

The test values ($F_{failure}$) are used to determine the flexural strength (σ_b) using the following formula:

$$\sigma_{b,mv} = \frac{6 \times F_{failure} \times L}{32 \times W}$$

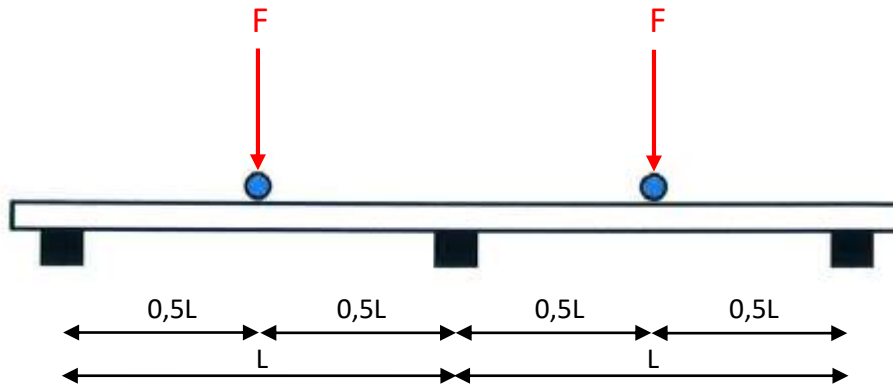

figure 10: Test setup multi-span

Wherein: L = span see table 7
W = section modulus mm³

table 7: Test results flexural strength multi-span

Sample nr.	L [mm]	F _{failure} [N]	σ _{b,min} [N/mm ²]
1	1200	35820	303
2	1200	41400	350
3	1200	38225	323
4	1200	36295	307
5	1200	34210	289
6	1200	41195	349
7			
Average [σ _{b,gem}]			320
Standard deviation [s]			25
Characteristic value [σ _{b,kar}]			266

The characteristic value is determined from the average value minus 2,18 x the standard deviation.

A.3.4 Shear strength

The shear strength is determined based on the test performed by krafton® on 14-04-2021.

The test values ($F_{failure}$) are used to determine the shear strength (τ) using the following formula:

$$\tau = \frac{F_{failure} \times (L - a)}{L \times A_s}$$

The test was performed at a span of $L = 200\text{mm}$. The press forms a line load on the sample and has a diameter of 100mm . The distance between the press and the support was $a = 100\text{mm}$.

Table 8: Test results shear strength

Sample nr.	$F_{failure}$ [N]	τ [N/mm ²]
1	115981	55,1
2	117820	56,0
3	110923	52,7
4	118195	56,2
5	110834	52,7
6	116579	55,4
Average [τ_{gem}]		54,7
Standard deviation [s]		1,6
Characteristic value [τ_{kar}]		51,2

The characteristic value is determined from the average value minus $2,18 \times$ the standard deviation.

A.3.5 Shear strength for a concentrated load on 200x200 mm

The shear strength for a concentrated load on 200x200 mm is determined based on the test performed by krafton® on 22-10-2018.

The test values ($F_{failure}$) are used to determine the shear strength (D_{200}) using the following formula:

$$D_{200} = \frac{F_{failure} \times (L - L_0)}{L}$$

This only applies to a load on 200x200 mm. The value L_0 is equal to half the length of the concentrated load surface, plus the distance between the support and the edge of the concentrated load.

Table 9: Test results shear strength concentrated load on 200x200mm

Sample nr.	L [mm]	L_0 [mm]	$F_{failure}$ [N]	D_{200} [N]
1	400	200	126067	63034
2	400	200	115779	57889
3	400	200	123300	61650
4				
5				
6				
Average [$D_{gem,200}$]				60858
Standard deviation [s]				2662
Characteristic value [$D_{kar,200}$]				51886

The characteristic value is determined from the average value minus 3,37 x the standard deviation.

A.3.6 Shear strength for a concentrated load on 100x100 mm

The shear strength for a concentrated load on 100x100 mm is determined based on the test performed by krafton® on 14-04-2021.

The test values ($F_{failure}$) are used to determine the shear strength (D_{100}) using the following formula:

$$D_{100} = \frac{F_{failure} \times (L - L_0)}{L}$$

This only applies to a load on 100x100 mm. The value L_0 is equal to half the length of the concentrated load surface, plus the distance between the support and the edge of the concentrated load.

Table 10: Test results shear strength concentrated load on 100x100mm

Sample nr.	L [mm]	L ₀ [mm]	F _{failure} [N]	D ₁₀₀ [N]
1	1000	55	38314	36207
2	1000	55	37435	35376
3	1000	55	38918	36778
4	1000	55	37990	35901
5	1000	55	38793	36659
6	1000	55	36069	34085
Average [$D_{gem,200}$]				35834
Standard deviation [s]				998
Characteristic value [$D_{kar,200}$]				33658

The characteristic value is determined from the average value minus 2,18 x the standard deviation.